

(Agenda Item nr. 5, The 2nd PHLG Meeting, 16 October 2006, Skopje)

PROPOSAL FOR SIMPLIFICATION AND HARMONISATION OF TRANSMISSION CAPACITY ALLOCATION PROCEDURES

- Working Plan -

Background

According to the Conclusions No. 34 of the 1st PHLG meeting held on 17-18 October 2006 in Vienna, the ECS was requested to submit a proposal for simplifying and harmonising electricity capacity allocation procedures in particular in UNMIK, Albania, Serbia and Montenegro. The ECS was requested to provide a working plan at the next PHLG meeting¹.

Purpose

The purpose of this paper is to identify problems and present a working plan to counteract the existing complexities associated to the allocation of capacity at the interconnectors, which hampered the security of supply in the last winter (2005-2006). General intention is to advance towards a compatible approach in the application of different allocation procedures of transmission capacity on the borders of the central part of the SEE region and to improve prospects for the SoS in this winter (2006-2007). Therefore, this working plan proposes activities which can be realised in the short-term time horizon (Dec 2006 – March 2007), but does not exclude the ones anticipated as necessary in the medium-term horizon. Moreover, it does not deal neither with the inter TSO compensation mechanism nor with the charges for access to networks, as it is not asked for, although it might make the plan incomplete. Additionally these topics could bring into the discussion the ownership dispute which is not a priority for the short-term SoS shortage that this paper is addressing. The intention is to provide the minimum degree of harmonisation required to achieve effective allocation of cross border capacities and not to go beyond what is necessary for that purpose.

Objectives

This working plan outlines in a structured and integrated way how the simplification and harmonisation will be addressed. It builds on provisions of the Treaty establishing the Energy Community and on the work of its institutions, but incorporates the essences of work done by other European and international institutions. The objective is to address in a single framework the areas where specific actions should be taken, specific actions themselves which should be taken, authorities that would be responsible for the implementation of respective actions, timeframe for completion of action, eventually needed financial support for each action, and referential documents and comments.

¹ **Disclaimer:** Kosovo is currently under international administration according to Resolution 1244 of the United Nations Security Council. Its future status would be determined by the ongoing status process led by Mr Martti Ahtisaari, Special Envoy for the Future Status Process for Kosovo. Therefore, at this moment, lack of clarity on political status deprives Kosovo of necessary clarity on the economic status as well. The Belgrade – Prishtine Dialogue has however now been largely overshadowed by the status process. This will require major revision in 2007 in the light of the outcome of the status process. However, this paper can be only taken as based on the Treaty establishing the Energy Community, and not prejudging any result of the plan for final status of Kosovo. Its sole aim is to answer to technical challenges stated in the Conclusions No. 34 of the 1st PHLG meeting, as according to the EnC Treaty (Art. 67b) the Secretariat shall review the proper implementation by the Parties of their obligations under the Treaty, and submit yearly progress reports to the Ministerial Council.

Context

In order to address this issue properly, it is necessary to explain the context of the task given to the Secretariat. Besides its obvious technical component, it also lays a political one. Serbia and UNMIK are two separate signatories of the EnC Treaty, and together with the other seven make a total of nine Contracting Parties. Both, Serbia and UNMIK, as well as all other Contracting Parties, need to start implementing the commitments undertaken in the framework of the EnC Treaty. One of the requirements is to establish a functioning TSO, which, among its tasks, shall be responsible for managing energy flows on the system taking into account exchanges with other interconnected systems. In Serbia, EMS has been appointed and licensed as TSO in July 2005 and June 2006, respectively. In UNMIK, in June 2006 the PISG of Kosovo nominated the Kosovo Transmission System and Market Operator J.S.C (KOSTT) as TSO and MO enterprise in Kosovo, while ERO licensed it in October 2006. KOSTT was part of a vertically integrated public energy enterprise KEK. Process of unbundling started a year ago and finished with establishment and nomination of KOSTT as TSO and MO. It is important to point out the eventual overlapping of authority in the allocation of interconnecting transmission capacity, which shall be avoided.

Problems

Three groups of problems are identified relating to current capacity allocation practices in the SEE region. Firstly, there is a lack of coordination between neighbouring TSOs in the allocation of capacity. At the most, some neighbouring TSOs have agreed to split the capacity, with each TSO applying a different method within its control area. In order to optimise the allocation of capacity, neighbouring TSOs and the respective regulatory authorities should agree on a coordinated approach, including a review for the calculation of the NTC values. This practice, which is underway within the EU-25 will represent an important step forward towards the optimisation of the capacity at the interconnectors. Secondly, the region depends heavily on imports given its lack of domestic generation, which is further aggravated by non-operation of oil fired power plants located in affected region due to high costs. As their generation prices are higher than expected market ones in this period (€55-60/MWh), it is not likely that they are going to enter into operation without a subsidy (in oil). Aiming to guarantee security of supply, the most extended solution is based on import tenders, where the importing TSO guarantees the long-term allocation of capacity. Third area of dispute is related to the borders, where the authority over the capacity allocation has a significant impact to the SEE region as a whole.

Borders

Resolution of authority over the capacity allocation has two possible scenarios. In the 'business as usual' one, EMS continues to allocate capacities on the borders of Serbia, including UNMIK ones. Number of borders and interconnecting lines stays the same. In the 'business unusual' scenario, KOSTT overtakes authority and starts to allocate capacity on the UNMIK borders. In the former scenario, EMS continues to treat KOSTT as part of its control area. The latter scenario calls, at least, for rearrangement of borders between the TSOs in the SEE region, if not for establishment of a new control area (Figures 1 and 2, Appendix 1). As KOSTT becomes new agent and independent of EMS, new interconnecting lines appear between EMS and KOSTT (L407 and L205). Furthermore, EMS loses and KOSTT gains authority to allocate capacity on the borders to MEPSO (L420), EPCG-TSO (L437) and ATSO (L2303). Rearrangement of borders in this scenario means basically increase of their number. Increased number of borders usually decreases transmission capacity available at the regional level, but without further computational analysis it is not possible to conclude on this in exact terms.

TSOs

Irrespective of the scenario chosen, bilateral communication between EMS and KOSTT on capacity allocation has no alternative should all TSOs be enabled to have sufficient access to all borders in the region, so difficulties experienced in the last winter with especially import of electricity can be avoided in this one. Quite often, the TSOs in the region have problems with import of electricity not only because of lack of cross border transmission capacity, but also because of congestions experienced in internal networks. Although technically possible and fairly often, it always gives thoughts on correctness in methodological approach and final results. Besides bilateral communication between EMS and KOSTT, the multilateral one which would include other affected TSOs in the region is more than welcome, as in the second scenario they need to use new communication addresses, channels and procedures. The problem is also that this part of the SEE region suffers from lack of domestic generation capacity and heavily depends on import, which TSOs in net importing countries try to secure through long-term reservation of cross border transmission capacities.

Regulators

While TSOs are operationally responsible to ensure security of supply and to run the operation of the system, the role of regulators can not be underestimated, as it opens another perspective of the allocation of cross border capacities. The regulators grant licences to TSOs which are obliged to implement a set of technical codes and rules. One of these is, in this case, the rules on allocation and use of cross border capacities as aligned to Regulation 1228/2003/EC (Arts. 5-6, Annex). National regulatory authorities should ensure compliance with the Regulation and the guidelines adopted on its basis (Art. 9). If they would have opposite positions, they can bring the case to the attention of the Energy Community Regulatory Board. As the Board is not yet operational, there is currently no other institution under the EnC Treaty which shall advise the Ministerial Council or the Permanent High Level Group on the details of statutory, technical and regulatory rules, and issue recommendations on cross-border disputes involving two or more regulators, upon request of any of them (Art. 58 of the EnC Treaty). A very good example of how the regulators can make a critical impact to integration of wholesale markets is a jointly prepared consultation document by CREG, CRE and DTe, which defined a common approach or road map for progressive regional integration of the three markets (Belgium, France and the Netherlands).

Traders

EFET has set out its own vision for addressing the fundamental questions associated with cross-border electricity trading, namely: 1) How should cross-border capacity be allocated and what methods qualify as market based ones; 2) How should congestion be managed and what methods qualify as market based; 3) How to maximise the physical amount of cross-border capacity and ensure the maximum allocation and usage of that capacity; and 4) How should revenues stemming from the sale of capacity rights be used by the TSO. EFET proposes some solutions to guide market players and authorities in the next phase of development of national and regional markets.

Referential Documents

Referential documents made by various institutions and related to the allocation of transmission capacity are publicly available at respective web sites of the institutions. Non-exhaustive list is provided in the Appendix 2 as to give a flavour of type and scope of the work done by EC, ETSO, SETSO TF, UCTE, ERGEG, EFET, Eurelectric, and USAID/NARUC.

Working Plan (summary)

I	II	III	IV	V
No	ACTION SUB-TASKS	RESPONSIBLE AUTHORITY	COMPLETION TIMEFRAME	REFERENCE DOCUMENTS, COMMENTS AND STATUS OF ACTION AND SUB-TASKS
1.	Borders and authority over allocation of capacity of cross-border inter-connecting lines (case Serbia and UNMIK)			
a	Establishment and licensing of the TSOs, adoption and implementation of the technical rules	Govs, MEMs, TSOs, Regulators	Till Dec 2006	Basic prerequisites for the allocation of cross border transmission capacities.
b	Establishment of an ad hoc group between TSOs and regulators relating to the allocation	TSOs, Regulators	Nov 2006	Ad hoc group is aimed to analyse and synthesize proposals relating to the allocation of capacity in the critical period. To be composed of representatives from UNMIK, Albania, Serbia and Montenegro, and eventually of other interested parties.
c	Membership of KOSTT in SETSO TF and its working sub-groups	KOSTT, ETSO, SETSO TF	Nov 2006	Application of KOSTT for membership and consequent approval from ETSO SC and SETSO TF. Proposal for collaboration mechanism among TSOs.
d	Proposal for the number of electrical borders for the winter 2006-2007	ETSO, SETSO TF, Regulators	Nov 2006	Also, taking into account the SoS concerns and the limited time before the winter.
e	Proposal for bilateral (or multilateral, if possible) transitional coordinated capacity allocation mechanisms on each border	TSOs, Regulators	Dec 2006	Including the allocation rules, nomination timeframes, firmness of the allocation, definition of 'Force Majeure', publication of data, etc
f	If requested, inclusion of the Energy Community Regulatory Board in resolution of eventual dispute	ECRB, PHLG, MC	2007	On the basis of the Treaty establishing the Energy Community.
2.	Coordination between neighbouring TSOs and regulators in the allocation of capacity			
a	Guidance Notes, list of recommendations and proposals from various contributors – General	ETSO, SETSO TF, NACMPF SG, Consentec, APCS, SECI TSPG, TSOs, Regulators	Dec 2006	Including the most suitable method, shared findings from significant projects, and revision of long term contracts.
b	Set of agreements on transmission allocation or mutual understanding on the most important items	TSOs	Dec 2006	Terminology, process timing, data format, netting, assessment and share, method, bilateral details, frequency, nomination obligations, transfer of capacity

I	II		III	IV	V
No	ACTION SUB-TASKS		RESPONSIBLE AUTHORITY	COMPLETION TIMEFRAME	REFERENCE DOCUMENTS, COMMENTS AND STATUS OF ACTION AND SUB-TASKS
					rights, capacity re-selling, return of allocated capacity, UIOLI, direction, information exchange, coordination of maintenance, DACF, and Force Majeure.
c		Harmonisation of calendars of monthly allocation procedure for the month M	TSOs	Dec 2006	Publication of transmission allocation rules; Publication of transmission capacity values; Final deadline for submission of applications; Analysis of applications; Information on results of allocation procedure; Date of contract signature; Start of using the allocated capacity.
d		Harmonisation of activities on calculation of cross border transmission capacity values for the month M in the winter 2006-2007 (including weekly basis)	TSOs	Dec 2006	Including following activities: time schedule, harmonisation of the tables, exchange of models, calculation, bilateral harmonisation of values, dissemination of calculated values.
f		Set of nomination and publication requirements for the month M in the winter 2006-2007	TSOs (and Regulators)	Dec 2006	Including nomination of responsible institution, method, procedure, rules, approval, values, results, and use.
g		Application of the three-step congestion management process on the daily basis during the critical period of the winter 2006-2007	TSOs	Dec 2006	In three steps from capacity allocation till the final execution of the transaction: D-1 (morning), D-1 (afternoon), and D (real time).
h		Set of agreements to be applied and proposals to be analysed in the period after the next winter 2006-2007 for the whole following year 2007	TSOs, Regulators, Traders	Jan 2007 - Dec 2007	Including harmonisation of allocation rules and computational procedures, publication obligations, bidding details, monitoring tasks, transparency, Force Majeure...
3.	Domestic production as a remedy to dependence on imports of electrical energy (oil-fired power plants in the SEE region)				
a		Proposal for activation of available, but costly generation capacity in the affected region (especially oil-fired power plants)	TSOs, Regulators	Nov 2006	As a short term remedy to alleviate import problems and congestions.

Working Plan (detailed)

I	II	III	IV	V
No	ACTION SUB-TASKS	RESPONSIBLE AUTHORITY	COMPLETION TIMEFRAME	REFERENCE DOCUMENTS, COMMENTS AND STATUS OF ACTION AND SUB-TASKS
1.	Borders and authority over allocation of capacity of cross-border inter-connecting lines			
a	Establishment and licensing of the TSOs, adoption and implementation of the technical rules	Govs, MEMs, TSOs, Regulators	Till Dec 2006	Basic prerequisites for the allocation of cross border transmission capacities.
	Establishment of EMS as TSMO	RS Gov, EPS, EMS	1 July 2005	
	Establishment of KOSTT as TSMO	MEM, KEK, KOSTT	1 July 2006	WB: ESTAP III EAR: ITSMO Operationalisation
	Licensing of EMS for TSO and MO	AERS	16 June 2006	
	Licensing of the KOSTT for TSO and MO	ERO	4 Oct 2006	
	Grid Code, Market Rules, other technical and commercial codes – Serbia	EMS, AERS		Draft by operator; approval by regulator.
	Grid Code, Transitional Market Rules, other technical and commercial codes – UNMIK	KOSTT, ERO	By 31 Dec 2006	Draft by operator; approval by regulator.
	Rules on allocation and use of cross border capacities – Serbia	EMS	Temp. appl. (1 Nov 2006 – 31 Dec 2006)	Available on the web page of EMS. Version 4.0, October 2006
	Rules on allocation and use of cross border capacities - UNMIK	KOSTT, ERO		Not available yet.
b	Establishment of an ad hoc group between TSOs and regulators relating to the allocation	TSOs, Regulators	Nov 2006	Ad hoc group is aimed to analyse and synthesize proposals relating to the allocation of capacity in the critical period. To be composed of representatives from UNMIK, Albania, Serbia and Montenegro, and eventually of other interested parties.
	Peer review of existing problems related to the cross border capacity values across each border	TSOs, Regulators	Dec 2006	Discuss current TTC, TRM, NTC, AAC, and ATC values.
c	Membership of KOSTT in SETSO TF and its working sub-groups	KOSTT, ETSO, SETSO TF	Nov 2006	Application of KOSTT for membership and consequent approval from ETSO SC and SETSO TF. Proposal for collaboration mechanism among TSOs.
	Application of KOSTT for full membership in SETSO TF and its working sub-groups	KOSTT to ETSO and SETSO TF	Nov 2006	

I	II	III	IV	V
No	ACTION SUB-TASKS	RESPONSIBLE AUTHORITY	COMPLETION TIMEFRAME	REFERENCE DOCUMENTS, COMMENTS AND STATUS OF ACTION AND SUB-TASKS
	Resolution of application of KOSTT for full membership in SETSO TF and its working sub-groups	ETSO, SETSO TF	Nov 2006	
	Proposal of mechanism for collaboration among TSOs, and if positively answered, draft of a road map for process leading to the accession of KOSTT to SETSO TF	ETSO, SETSO TF	Nov 2006	
d	Proposal for the number of electrical borders for the winter 2006-2007	ETSO, SETSO TF, Regulators	Nov 2006	Also, taking into account the SoS concerns and the limited time before the winter.
	Agreement or decision on rearrangement or non-rearrangement of the borders and consequent authorisation over cross border capacity allocation	ETSO, SETSO TF, EMS, KOSTT	Nov 2006	
	In case of positive answer to the application from the action 2.c and consequent agreement/decision from the action, re-drafting of the SETSO TF documents related to capacity allocation in SEE region	SETSO TF, NACMPF SG	Dec 2006	Literature [3-6]
	In case of negative answer to the application from the action 2.c, continuation of cooperation on the basis of bilateral agreements	EPS, EMS, KEK, KOSTT	Dec 2006	The Temporary Technical Agreement and the Temporary Energy Exchange Agreement signed on 26 March 2001 between UNMIK-PUD and MEM RS.
	Circulation of information on outcomes of the action 2.c to other TSOs in the region; bilateral and multilateral communication	EMS, KOSTT, ETSO, SETSO TF	Dec 2006	
e	Proposal for bilateral (or multilateral, if possible) transitional coordinated capacity allocation mechanisms on each border	TSOs, Regulators	Dec 2006	Including the allocation rules, nomination timeframes, firmness of the allocation, definition of 'Force Majeure', publication of data, etc
	Development of methodology and implementation mechanism, including publication of data for cross border capacity allocation	SETSO TF, NACMPF SG	Dec 2006	
f	If requested, inclusion of the Energy Community Regulatory Board in resolution of eventual dispute	ECRB, PHLG, MC	2007	On the basis of the Treaty establishing the Energy Community.
	In case of continuously opposite positions, the regulators can bring the case to the attention of the Energy Community Regulatory Board	ERO, AERS, ECRB	2007	The Regulatory Board has not been established yet nor operationally capable to take its tasks soon.
	If asked to do so, the Regulatory Board shall advise	ECRB, PHLG,	2007	Art. 58 of the EnC Treaty.

I	II	III	IV	V
No	ACTION SUB-TASKS	RESPONSIBLE AUTHORITY	COMPLETION TIMEFRAME	REFERENCE DOCUMENTS, COMMENTS AND STATUS OF ACTION AND SUB-TASKS
	the Ministerial Council or the Permanent High Level Group on the details of statutory, technical and regulatory rules, and issue recommendations on cross-border disputes involving two or more regulators, upon request of any of them	MC		
2.	Coordination between neighbouring TSOs and regulators in the allocation of capacity			
a	Guidance Notes, list of recommendations and proposals from various contributors – General considerations	TSOs, Regulators, Consultants	Dec 2006	Including the most suitable method, shared findings from significant projects, and revision of long term contracts.
	The most suitable transmission capacity allocation method in the SEE region for the next winter 2006-2007	ETSO, SETSO TF, NACMPF SG	Dec 2006	Including description of the position concerning Congestion Management (CM) in the SEE region, work already done, principles to be applied, work to be done, next concrete steps to functioning, effective and transparent Congestion Management. Bilateral vs. coordinated capacity allocation. Curtailment based on NTCs vs. bilateral auctioning. Coordinated auctioning.
	Shared findings from the KfW financially supported project 'Investigation and Implementation of Transfer Capacity Allocation Methods for Electricity in SEE'	Consentec, APCS	Dec 2006	Including technical, organisational and juridical perspective.
	Detection of congestions in the SEE region	SECI TSPG	Dec 2006	Shared findings from the two concurrent project studies: 1) Transmission Network Investment Criteria, and 2) Evaluation of Investments in Transmission Network to Sustain Generation and Market Development in SEE.
	Inclusion of the cross border transmission capacity allocation into the SEE Market Monitoring Pilot Project	USAID, NARUC, Potomac Economics, U Cambridge, U Budapest, TSOs, Regulators	Dec 2006	Including monitoring of transparency requirements, market power, competitiveness vs. SoS, and wholesale prices. Reveal evidences of anticompetitive conduct related to congested periods (focus on transmission outages, generation dispatch, power flows on congested facilities, and prices charged for wholesale power).
	Revision of long term contracts which have pre-emptive allocation	TSOs, Regulators	Dec 2006	Already allocated capacity (AAC).

I	II		III	IV	V
No	ACTION SUB-TASKS		RESPONSIBLE AUTHORITY	COMPLETION TIMEFRAME	REFERENCE DOCUMENTS, COMMENTS AND STATUS OF ACTION AND SUB-TASKS
b	Set of agreements on transmission allocation or mutual understanding on the most important items	TSOs	Dec 2006	Terminology, process timing, data format, netting, assessment and share, method, bilateral details, frequency, nomination obligations, transfer of capacity rights, capacity re-selling, return of allocated capacity, UIOLI, direction, information exchange, coordination of maintenance, DACF, and Force Majeure.	
	Agreement on harmonisation of terminology, process timing and data format	TSOs	Dec 2006	Terms, acronyms, abbreviations, calendars, information.	
	Agreement on netting (with or without)	TSOs	Dec 2006	TSOs shall net the capacity requirements in opposite direction in order to use the line to its maximum capacity.	
	Agreement between neighbouring TSOs (contract on capacity assessment and share)	TSOs	Dec 2006	Including details of procedure, namely data exchange, capacity assessment, congestion forecast at different timeframes.	
	Agreement on installation of bilateral allocation method	TSOs	Dec 2006	Priority list, pro rata rationing, explicit auction, implicit auction.	
	Agreement on details of common bilateral allocation	TSOs	Dec 2006	Unilateral method, capacity split 50:50, joint method.	
	Agreement on details of frequency of bilateral allocation	TSOs	Dec 2006	Yearly, monthly, daily allocation.	
	Agreement on identical obligations in the allocation procedure	TSOs	Dec 2006	Nomination, timeframes, offered products, closing times, validation, bidding/clearing procedure, congestion charges, and contractual framework.	
	Agreement on possible transfer of capacity rights between market participants	TSOs	Dec 2006	Re-selling of the capacity. Return of allocated capacity, including lead time, border and direction. Participant to whom the capacity has been allocated (border, direction) may be allowed to transfer the capacity right to another one, but only with approval of TSO. Notification of the transfer shall be given to TSO at least 2 days prior to the starting date of transfer. Request has to contain capacity value to be transferred, period to which the right is to be transferred and borders of transmission. Capacity right may be transferred only to participant who participated in the monthly allocation procedure. TSO reviews the request, decides and informs participants on the decision.	
Agreement on application of UIOLI principle	TSOs	Dec 2006	Each right to use the transmission capacity which is not nominated to TSO according to the UCTE		

I	II	III	IV	V
No	ACTION SUB-TASKS	RESPONSIBLE AUTHORITY	COMPLETION TIMEFRAME	REFERENCE DOCUMENTS, COMMENTS AND STATUS OF ACTION AND SUB-TASKS
				Policies/Timelines shall be lost without any compensation on the basis of UIOLI principle.
	Agreement on direction	TSOs	Dec 2006	Import, export, both.
	Agreement on exchange of information between TSOs	TSOs	Dec 2006	Range and format of data. Mutual exchange of information on coordination of maintenance of interconnecting lines. 'TSOs to TSOs' and 'Market Participants to TSOs' data exchanges. Time horizon: real time/intra day, one/two days ahead, and medium/long term.
	Agreement on day ahead congestion forecast (DACF) procedure	TSOs	Dec 2006	Network model data exchange.
	Agreement on common definition of 'Force Majeure' for the next winter 2006-2007 and limitation of usage of transmission capacity	TSOs	Dec 2006	Definition of sudden crisis and other emergency events. TSO may limit the participants in usage of capacity rights because of unexpected decrease of ATC values, not obeying UCTE rules on reporting and harmonising exchange programs, not using allocated capacity longer than 2 days without prior notification to TSO. Participants do not have right to claim financial compensation in case of limitation of allocated capacity rights. If possible, consider sudden shortages in generation capacity in neighbouring systems as 'Force Majeure' cases.
c	Harmonisation of calendars of monthly allocation procedure for the month M	TSOs	Dec 2006	Publication of transmission allocation rules; Publication of transmission capacity values; Final deadline for submission of applications; Analysis of applications; Information on results of allocation procedure; Date of contract signature; Start of using the allocated capacity.
	Publication of transmission allocation rules in the (M-1) month for usage in the month M	TSOs	Dec 2006	All details concerning allocation rules shall be known sufficiently in advance. Preferably, by the 10 th day of month (M-1).
	Publication of transmission capacity values for the month M	TSOs	Dec 2006	Following, at the minimum, shall be published: allocation unit (border and direction), symbol of the unit, TTC, TRM, NTC, AAC, ATC, period of validity, fees (CBCRF in case of congestions and MAF for monthly administration). Preferably, by the 20 th day of month (M-1).
	Submission of applications for transmission capacity allocation in the month M, according to harmonised	Participants to TSOs	Dec 2006	Formal application shall contain harmonised set of information. Following, at the minimum, shall be provided:

I	II	III	IV	V
No	ACTION SUB-TASKS	RESPONSIBLE AUTHORITY	COMPLETION TIMEFRAME	REFERENCE DOCUMENTS, COMMENTS AND STATUS OF ACTION AND SUB-TASKS
	set of information			general data (company coordinates, EIC code, and authorised representatives), profile of requested daily capacity on hourly basis (border, MW, time interval from/to). Preferably, by the 25 th day of month (M-1).
	Analysis of applications for transmission capacity allocation in the month M	TSOs	Dec 2006	TSO shall review all the applications received and classify them according to allocation criteria. Participants, who do not obey the UCTE rules on scheduling of power exchange (UCTE OH Policy 2), will not be allowed to participate in capacity allocation and their applications will not be taken into account. Preferably, by the 28 th day of month (M-1).
	Provision of information to applicants on results of allocation procedure for the month M	TSOs to Participants	Dec 2006	TSO shall draw up an answer to the applicants that will provide either the offer to carry out the access service of interconnecting lines or the denial of the service, with presentation of the reasons. At the minimum, it shall contain the following: allocation unit (border, direction), symbol of the unit, ATC, period of validity, total sum of allocated capacity, fee (CBCRF in case of congestions). Preferably, on the 28 th day of month (M-1).
	Contracting the capacity allocation for the month M	TSOs and Participants	Dec 2006	TSO's offer for the capacity allocation has to be accepted and confirmed by the applicant, otherwise the request is cancelled and a new application has to be registered. The contract may be subject to conditionality (demand of financial collaterals, cancellation policy, 'Force Majeure' situations). Preferable date for the contract signature, on the 29 th day of month (M-1).
	Start of using the allocated capacity	Participants under surveillance of TSOs	Dec 2006	On the 1 st day of month M. TSO approves the exchange programmes only to those participants which have gotten the allocation rights (border, direction). Exchange programmes for day-ahead have to be submitted to TSO before 14:30 PM, afterwards it is not possible to modify the exchange programme. Prior to that, the programme has to be accepted and confirmed by the neighbouring TSOs. TSO may allocate remaining spare capacity (un-allocated capacity) on the weekly, day ahead and intra-day basis, but only to those participants who have participated in monthly capacity allocation. Remaining spare capacity on the day-

I	II	III	IV	V
No	ACTION SUB-TASKS	RESPONSIBLE AUTHORITY	COMPLETION TIMEFRAME	REFERENCE DOCUMENTS, COMMENTS AND STATUS OF ACTION AND SUB-TASKS
				ahead basis can be allocated to those participants, who submit their applications to TSO until 10:00 AM during the day prior to the day of usage.
d	Harmonisation of activities on calculation of cross border transmission capacity values for the month M in the winter 2006-2007	TSOs	Dec 2006	Including following activities: time schedule, harmonisation of the tables, exchange of models, calculation, bilateral harmonisation of values, dissemination of calculated values.
	Definition of the time schedule for making the transmission network model for calculation purposes for the month M in the winter 2006-2007 (snapshot models following UCTE standards)	TSOs	Dec 2006	For the 3 rd Wednesday in month M at 10:30 AM (monthly basis); Preferably weekly and daily DACF, perhaps hourly, for the SoS critical periods.
	Harmonisation of the BCE table in the base case model for calculation purposes for the month M in the winter 2006-2007	TSOs	Dec 2006	Till the 15 th day of month (M-2).
	Exchange of the network models with agreed totals and merging for calculation purposes for the month M in the winter 2006-2007	TSOs	Dec 2006	Till the 20 th day of month (M-2). Including the list with merit order for increasing/decreasing of the power plant generation during calculation of transfer capacities, definition of power flow limits...
	Calculation of transfer capacity values for the month M in the winter 2006-2007 (TTC, TRM, NTC, AAC, ATC)	TSOs	Dec 2006	From the 20 th till the 30 th day of month (M-2). Including consistency checks, totals check, corrections or updates of the model (optional), sending of the model to all TSOs...
	Bilateral (eventually multilateral) harmonisation of transfer capacity values for the month M in the winter 2006-2007 by the neighbouring TSOs	TSOs	Dec 2006	From the 30 th day of month (M-2) till the 4 th day of month (M-1).
	Sending of harmonised transfer capacity values for the month M in the winter 2006-2007 to all TSOs	TSOs	Dec 2006	On the 5 th day of month (M-1)
	Extension to calculation of composite (simultaneously feasible) transfer capacity values for certain borders in the SEE region through typical coupling and fractioning for the month M in the winter 2006-2007	TSOs	Dec 2006	In case that clear benefits can be recognised due to persisting power flow patterns.
	Formation of the common weekly transmission network models for calculation purposes in the weeks of the month M in the winter 2006-2007	TSOs	Dec 2006	On the basis of the common merged model for the 3 rd Wednesday 10:30 AM of month M, make the models for 1 st , 2 nd , and 4 th Wednesday.
	Calculation of different transfer capacity values on	TSOs	Dec 2006	Investigate possibility to execute this routine on a daily

I	II	III	IV	V
No	ACTION SUB-TASKS	RESPONSIBLE AUTHORITY	COMPLETION TIMEFRAME	REFERENCE DOCUMENTS, COMMENTS AND STATUS OF ACTION AND SUB-TASKS
	the weekly basis for the weeks of the month M in the winter 2006-2007 (TTC, TRM, NTC, AAC, ATC)			basis for the SoS critical periods.
	Bilateral (eventually multilateral) harmonisation of transfer capacity values for the 4 weeks of the month M in the winter 2006-2007 by the neighbouring TSOs	TSOs	Dec 2006	Including dissemination of calculated values to neighbouring TSOs.
e	Set of nomination and publication requirements for the month M in the winter 2006-2007	TSOs (and Regulators)	Dec 2006	Including nomination of responsible institution, method, procedure, rules, approval, values, results, and use.
	Nomination of institution which organises the allocation and announcement of its web address for publication of results	Regulators	Dec 2006	Web based. Nominate the institution and announce its web address, if non-existing.
	Publication of description of capacity allocation method applied	TSOs	Dec 2006	Web based. Draft the description, if non-existing.
	Publication of description of capacity allocation procedures	TSOs	Dec 2006	Web based. Draft the procedure, if non-existing.
	Publication of the documents containing the allocation rules	TSOs	Dec 2006	Web based. Draft the rules, if non-existing.
	Publication of approval of the allocation method by the Regulator	TSOs and Regulators	Dec 2006	Web based. Obtain the approval, if non-existing.
	Publication of transfer capacity values for the month M in the winter 2006-2007	TSOs	Dec 2006	Web based. Including TTC, TRM, NTC, AAC, and ATC.
	Communication of published results to ETSO for consecutive publication at ETSO web site for the winter 2006-2007 season	TSOs to ETSO	Dec 2006	Web based; Indicative values for Net Transfer Capacities (NTC); Reference case Winter 2006-2007 – Base Case agreed Exchanges.
	Publication of results of capacity allocation procedure for the month M in the winter 2006-2007	TSOs	Dec 2006	Web based. Including volumes per timeframe and prices per timeframe.
	Publication of capacity use information for the month M in the winter 2006-2007	TSOs	Dec 2006	Web based. Including total nominated flows per timeframe, corrective actions, and actual net physical flows.
f	Application of the three-step congestion management process on the daily basis during the critical period of the winter 2006-2007	TSOs	Dec 2006	In three steps from capacity allocation till the final execution of the transaction: D-1 (morning), D-1 (afternoon), and D (real time).
	D-1 (morning)	TSOs	Dec 2006	Evaluation and allocation of the transfer capabilities; Assessment performed at the borders where the desired amount of the power transfer exceeds offered capacity.
	D-1 (afternoon)	TSOs	Dec 2006	Analysis of the forecasted flows – DACF. The forecasted

I	II	III	IV	V
No	ACTION SUB-TASKS	RESPONSIBLE AUTHORITY	COMPLETION TIMEFRAME	REFERENCE DOCUMENTS, COMMENTS AND STATUS OF ACTION AND SUB-TASKS
				models of each TSO for all 24 hours of the next day were made and exchanged. Additional security analysis performed, possible congestions detected, countermeasures planned.
	D (real time)	TSOs	Dec 2006	Real-time security management. Counteract differences between forecast and real situation. Recognise inconsistencies between short-term ATC and physical flows. Congestion relief procedures to be applied on-line.
g	Set of agreements to be applied and proposals to be analysed in the period after the next winter 2006-2007 for the whole following year 2007	TSOs, Regulators, Traders	Jan 2007 - Dec 2007	Including harmonisation of allocation rules and computational procedures, publication obligations, bidding details, monitoring tasks, transparency, Force Majeure...
	Proposal for harmonisation of the capacity allocation rules	TSOs	Jan 2007	Literature [1], Art. 3.5. Including allocation times, timeframes, closing times, firmness levels, products' nominations, secondary markets, etc.
	Publication of the minimum of the yearly, monthly and daily capacities to be allocated for the whole following year 2007 on the borders	TSOs	Jan 2007	Literature [1], Art. 4.1.
	Bidding for the annual, monthly and day-ahead timeframes	Traders	Jan 2007	
	Implementation of a joint monitoring task force	Regulators	Jan 2007	Literature [1], Arts. 1.10, 3.2
	Proposal of harmonised rules for secondary trading of capacity rights	TSOs	Apr 2007	Literature [1], Art. 2.12
	Proposal for cross border intraday trade	TSOs	Apr 2007	Literature [1], Arts. 1.9, 2.1
	Proposal for a coordinated calculation of cross border capacities	TSOs	Apr 2007	Literature [1], Art. 3.5
	Publication of detailed list of transparency items	Regulators	Apr 2007	Literature [2, 10, 11, 14]. Literature [1], Arts. 5.1-5.10.
	Proposal for common definition of 'Force Majeure' for the continuing period	TSOs	Apr 2007	
	Implementation of common definition of 'Force Majeure' for continuing period	TSOs	July 2007	
	Implementation of harmonised rules for secondary trading of capacity rights	TSOs	July 2007	Literature [1], Art. 2.12
	Proposal for common coordinated congestion management method and capacity allocation	TSOs	July 2007	Literature [1], Art. 3.2. At least on a yearly, monthly and day-ahead basis. To mention the SEE region as well.

I	II	III	IV	V
No	ACTION SUB-TASKS	RESPONSIBLE AUTHORITY	COMPLETION TIMEFRAME	REFERENCE DOCUMENTS, COMMENTS AND STATUS OF ACTION AND SUB-TASKS
	procedure in SEE region			
	Publication of results of investigation of the coordinated explicit flow-based auctions dry-run period	TSOs	July 2007	Literature [5].
	List of recommendations for transmission capacity allocation methods in the SEE region for continuing period, preferably aligned to the Congestion Management Guidelines	ETSO, SETSO TF, NACMPF SG	July 2007	Literature [1]. Method, procedure, reserve prices, UIOLI/UIOSI, capacity reselling, coordination and common network model, publication
	Investigation into opportunity of quarterly and multi-annual allocation	Regulators	Oct 2007	
	Publication of the minimum of the yearly, monthly and daily capacities to be allocated for the following year (2008)	TSOs	Oct 2007	Literature [1], Art. 4.1.
	Investigation of the 'use it or get paid for it' rule	TSOs, Regulators	Oct 2007	
	Presentation of possibility to implement CAO	TSOs to Regulators	Oct 2007	Literature [5].
	Implementation of fully harmonised allocation rules between the borders, including common definition of 'Force Majeure' and a calculation method for cross border capacities	TSOs	Dec 2007	Literature [1].
	Implementation of benchmark list for transparency	Market participants	Dec 2007	Literature [2, 10, 11, 14]. Literature [1], Arts. 5.1-5.10.
	Proposal for cross border balancing	TSOs	Dec 2007	
3.	Domestic production as a remedy to dependence on imports of electrical energy			
a	Proposal for activation of available, but costly generation capacity in the affected region (especially oil-fired power plants)	TSOs, Regulators	Nov 2006	As a short term remedy to alleviate import problems and congestions.
	Review of available generation capacities in the SEE region in the winter period 2006-2007	TSOs, Regulators	Nov 2006	Inventory of available power plants and installed capacities.
	Recognition of all available generating power plants which are out of operation due to high marginal	TSOs, Regulators	Nov 2006	Case TPP Negotino, Macedonia (200 MW, oil-fired power plant, located in the affected region).

I	II	III	IV	V
No	ACTION SUB-TASKS	RESPONSIBLE AUTHORITY	COMPLETION TIMEFRAME	REFERENCE DOCUMENTS, COMMENTS AND STATUS OF ACTION AND SUB-TASKS
	costs			
	Consider activation of expensive generating power plants in affected regions in case of congestions which limit supply	EC, EAR, MEPSO, Regulator	Nov 2006	Assess operational capabilities of oil-fired TPPs, especially TPP Negotino. If capable to operate on continuous basis, consider its activation to relax congestions by volume.
	Consider costs of generation of oil-fired power plants and possible compensations for entering into the operation in the SoS critical period	EC, EAR, MEPSO, Regulator	Nov 2006	Subsidy in oil is needed to secure additionally available generation of TPP Negotino, 200 MW band, in the affected region. It is estimated that with intervention of M€2-3 per month the generation price of TPP Negotino can come to €55-60 per MWh (market price that MEPSO buys at in this period).
	Approximation of costs/subsidy needed to operate oil-fired TPP Negotino in the affected region (200 MW in band)	EC, EAR, MEPSO, Regulator	Nov 2006	Approximation: TPP Negotino needs 1,000 t per day of oil to generate 200 MW in band. At the price of €300 per t, it comes out that daily generation costs are around €300,000 per day. Calculating with 100 days of winter season (slightly more than 3 months), it makes M€30 per season. It is estimated that 25% of this total amount should be subsidized to bring the price to €55-60 per MWh, which makes the subsidy equal to M€7.5 per season. As this is just a rough approximation, it might be concluded that with the subsidy of M€6-9 per season (or M€2-3 per month), TPP Negotino can be put into operation.

Appendix 1: UCTE Graphical Presentation of the Power System

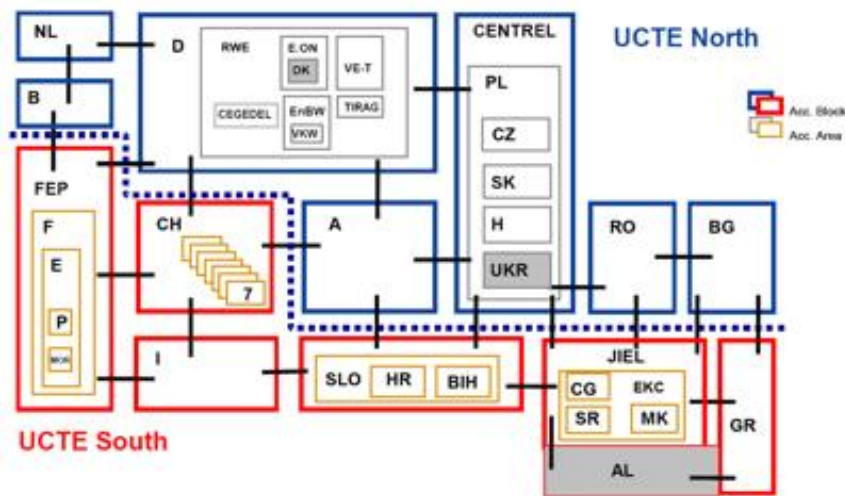

Figure 1. UCTE control areas and blocks

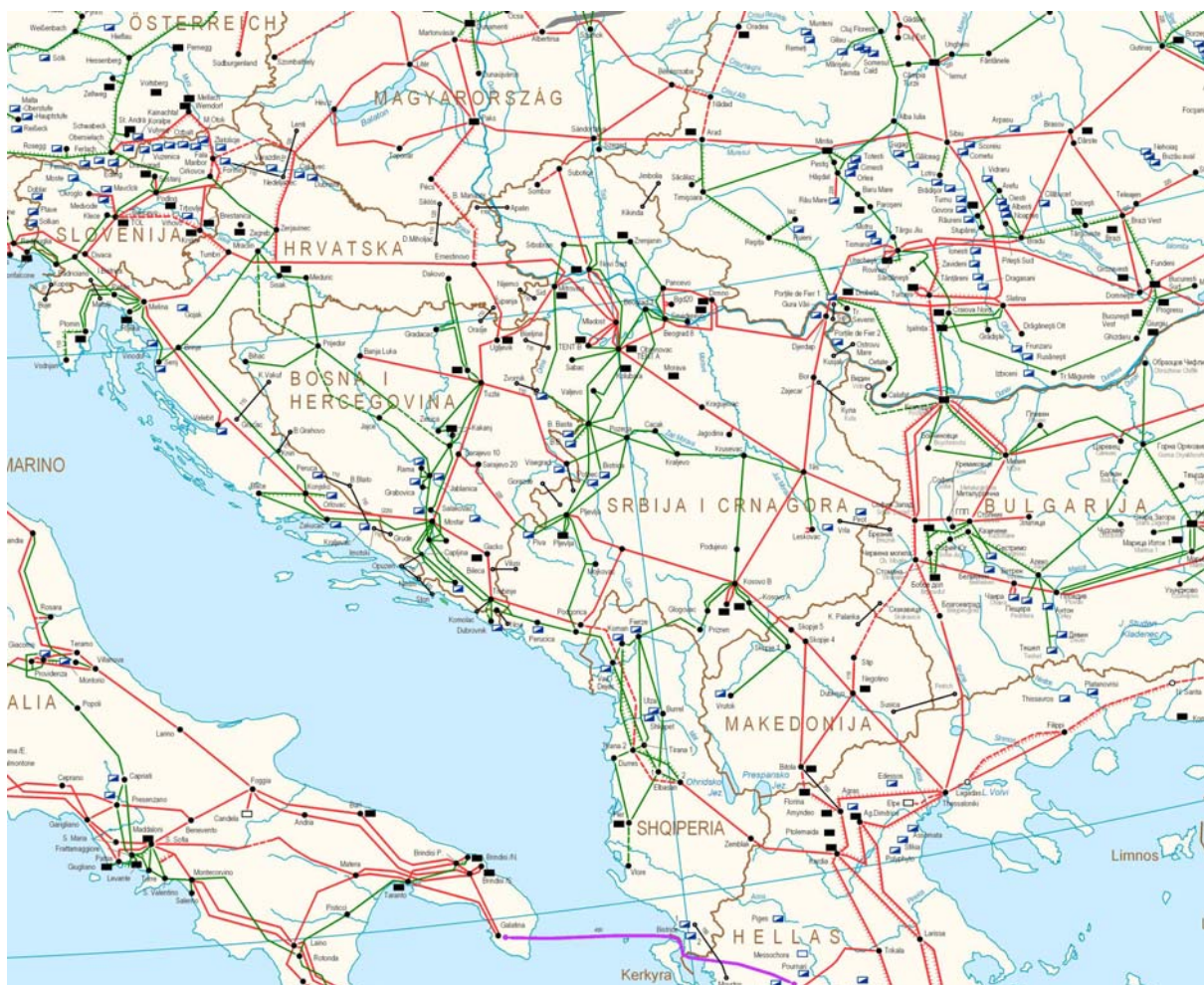

Figure 2. UCTE transmission system – the most affected part of the task

Appendix 2: Referential Documents

1. *'Draft Guidelines on the management and allocation of available transfer capacity of interconnections between national systems'*, The Annex to the draft Commission Decision amending the Annex to Regulation (EC) No 1228/2003 on conditions for access to the network for cross-border exchanges in electricity (draft currently under the comitology process within the European Union)
2. *'List of data European TSOs need to pursue for optimal use of the existing transmission infrastructure'*, ETSO, December 2005
3. *'Position paper on congestion management in south-eastern Europe region'*, SETSO TF, NACMPF SG, October 2003
4. *'Overview of currently applied methods for cross-border transmission capacity allocation in south-east Europe – Situation October 2005'*, SETSO TF, NACMPF SG, November 2005
5. *'Congestion management methods in SEE and work status of the Coordinated Auctions dry-run simulation – Situation October 2006'*, SETSO TF, NACMPF SG, October 2006
6. *'Internet and market information: overview of SEE TSOs' websites – Situation Spring 2006'*, ETSO, 2006
7. *'UCTE OH – Policy 4: Coordinated operational planning'*, UCTE, June 2005
8. *'UCTE OH – Appendix 4: Coordinated operational planning'*, UCTE, June 2005
9. *'UCTE OH – Policy 2: Scheduling and accounting'*, UCTE, July 2004
10. *'ERGEG Guidelines for good practice on information management and transparency in electricity markets'*, ERGEG, March 2006-11-02
11. *'Transparency of information about the availability and use of infrastructure and the promotion of competition in European wholesale power markets'*, EFET updated position, May 2006
12. *'Harmonising the operation of European wholesale electricity markets'*, EFET, March 2006
13. *'Reforming the management of electricity transmission congestion in the EU internal market: An EFET vision'*, EFET, October 2004
14. *'Survey on the implementation of market transparency requirements in countries involved in the Athens Process – Preliminary results'*, Eurelectric, WG Wholesale Markets & Trading, June 2006
15. *'Market monitoring pilot plan for south east Europe wholesale electricity market – Preliminary design concept'*, Potomac Economics sponsored by USAID/NARUC, November 2006
16. *'Regional market integration between the wholesale electricity markets of Belgium, France and the Netherlands – A road map'*, CREG, CRE and DTe, December 2005